

BL77-HD

Technical datasheet

NAM-BL77-HD-FT-EN-B

AS AUTOMATIC
SYSTEMS

Access controlled...

Future secured

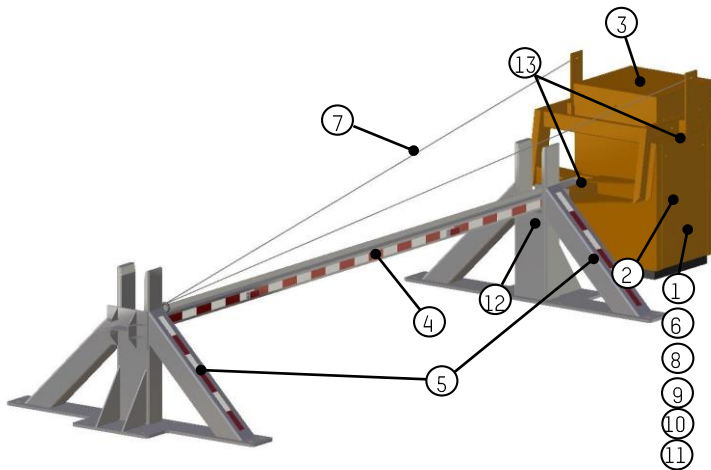

BL77-HD rising barrier is designed and manufactured by Automatic Systems. It is a unique product that effectively prevent vehicles from unauthorized access. BL77-HD barrier is typically used for medium traffic volume and single lane access point management.

It is used for asset protection in facilities such as court houses, police service buildings, etc. The BL77-HD offers free passage width up to 20' [6m]. It opens completely within 10 seconds.

IMPACT SIMULATION

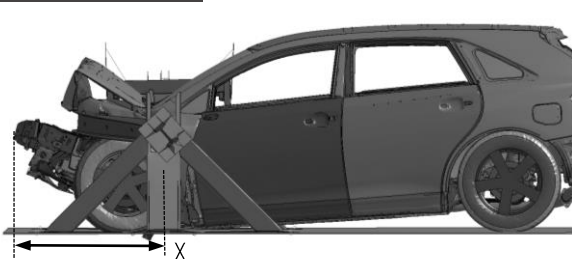

Barrier free passage length	Penetration 'X'	Max Vehicle speed
4m	3'10" [1.17m]	31mph [50km/h]
6m	4'8" [1.43m]	25mph [40km/h]

CONFIGURATION

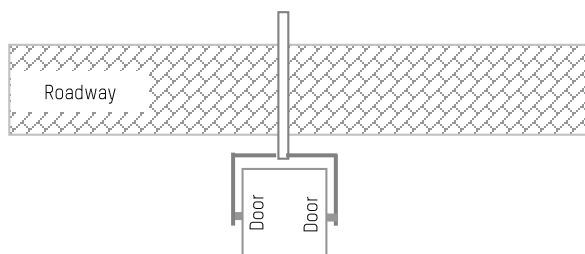

DESCRIPTION

- Operator cabinet** made of a strong welded steel frame up to 3/4" [19mm] covered with 14 gauge (2mm) sheet metal.
- Side panel** provides easy access to the mechanism (locked by key).
- Cover** is 14 gauge (2mm) thick, folded and welded steel sheets, lockable by key.
- Central arm**, painted white with red and white reflective stripes. There are two arm models depending on length :
 - 13' [4m] free passage barrier an IPN Beam S150x19.
 - Between 13'1" [4m] and 20' [6m] free passage barrier : an IPN beam S130x15
- Two bracing posts** to support the arm (anchored in concrete). Made of steel and painted white with red and white reflective stripes.
- Galvanized steel guy wires** for the arm.
- Electromechanical assembly:**
 - 3 phase instant-reversing 3/4 HP [559W] motor,
 - Speed reduction gearbox, with worm screw type mechanism.
 - Balancing achieved by means of integrated adjustable compression springs [2].
 - Crankshaft/rod device with steel abutments.
 - Analog sensor combined with speed controller allowing a smooth movement of the barrier and progressive acceleration and deceleration.
 - Safety torque limiter with adjustable friction disks.
 - Transmission between motor and gearbox by V-belt and pulleys.
- Integrated strip heater** for low temperatures down to -13°F [-25°C].
- Emergency crank** with safety switch for manual operation of the barrier in the event of a power failure.
- Audible Alarm** activated during movement.
- AS1320 control board** enabling various commands and/or accessory options
 - Possibility of 2 built in vehicle detectors allowing 4 detectors).
 - Overload protection
 - Terminal blocks for motor, detector relays, and options.
 - Dry contact output for information on the barrier or to command other equipment.
 - Status of the barrier's position (open or closed),
 - Status of the presence detectors,
 - Command for master-slave barriers (movement of one barrier controlled by the other barrier)
- Safety detection photocells**
- Anti-vandalism bolt covers.**

ANTI-CORROSION TREATMENT

- Zinc-coated internal mechanical parts.
- Complete body (housing, base plate, cover and doors):
A 4000 hour salt spray resistant primer followed by an AS RAL2000 orange powder paint coat.

STANDARD TECHNICAL CHARACTERISTICS

Input power ⁽¹⁾	240 VAC / 60 Hz (with ground)
Consumption	659 W (nominal) - 1159 W (max. with largest heater)
Motor	Three-phase 240 V / ¼ Hp [559 W]
Transmission	Gearbox and pulley
Arm Length (B)	17'4" to 23'11" [5.284 to 7.284m].
Free Passage (L)	13'1" [4m] to 19'8" [6m]
Operating temperature	-13°F to 122°F [-25°C to 50°C] without heater option
Relative Humidity	95% without condensation
Opening speed ⁽²⁾	10 sec
Closing speed ⁽²⁾	10 sec
Weight (without arm)	1408lbs (640kg)
Weight arm	172.5 to 227lbs (79 to 103kg)
Impact Rating	Impact simulation not rated Vehicle 3819.2lbs [1736 kg] at 13'1" [4m] free passage barrier: <ul style="list-style-type: none"> • Speed 31mph [50km/h] • Vehicle penetration 3'10" [1.17m] 19'8" [6m] free passage barrier: <ul style="list-style-type: none"> • Speed 25mph [40km/h] • Vehicle penetration 4'8" [1.43m]
MCBF ⁽³⁾	750 000 cycles <i>(with recommended maintenance)</i>

- (1) not to be connected to a floating network or to a high impedance earthed industrial distribution network
(2) adjustable through the control board
(3) Mean Cycle Before Failure

STANDARD DIMENSIONS (INCHES & MM)

Refer to the installation drawing.

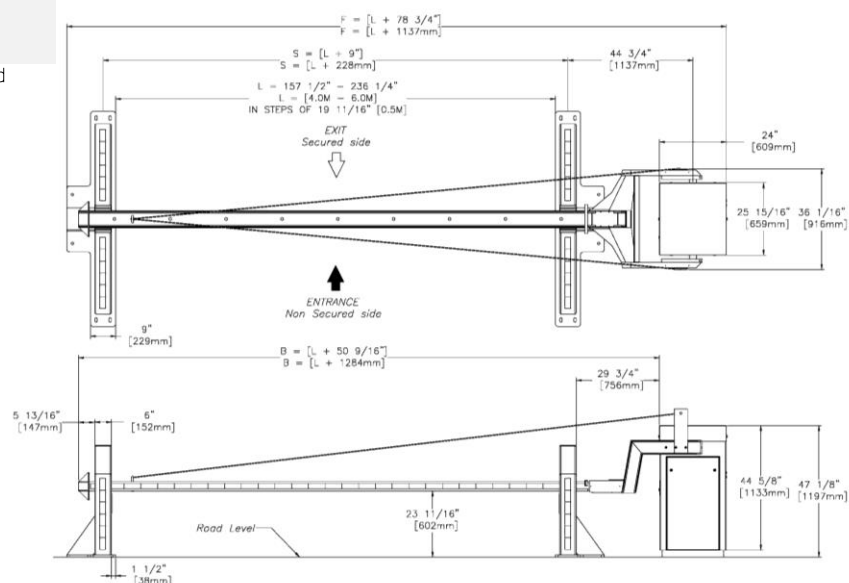
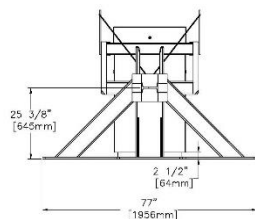

OPTIONS

1. STOP sign – 11 13/16 in [300 mm] diameter.
2. Traffic lights mounted on a standalone post
3. Push-button box.
4. Key switch (with captive or removable key)
5. Remote control.
6. Detection loop.
7. Presence detector for inductive loops.
8. Additional photocells to open, close or automatically stop/reopen the barrier arm.
9. Photocell support post (car or truck height)
10. AS1321 Input/Output extension board.
11. AS1049 board for third-party traffic signs.
12. Arm lights
13. Thermostatic heater for operation down to -49°F [-45°C]
14. Non-standard RAL colors.

For restrictions on options please speak to your sales representative.